



DIONICS, INC.

65 Rushmore Street
Westbury, NY 11590

Phone: (516) 997-7474

Fax: (516) 997-7479

Website: www.dionics-usa.com

DIG-11-8-30-DD; DIG-12-08-30-DD; DIG-22-8-30-DD

Photovoltaic MOSFET Drivers With Dynamic Discharge*

*US Patent 4,931,656

Features:

- Fast Turn Off, Active Gate Discharge
- Dielectrically Isolated
- Logic Circuit Compatibility
- High Open Circuit Voltage
- High Operating Temperature
- Fast Response Time
- High Isolation Resistance
- Excellent Input/Output Linearity
- Self Limiting Gate Voltage

Applications:

- Gate Drive For MOS devices
- Gate Drive For SCR
- Solid-State Relays
- Interface Between Logic Circuits & External Loads
- A.T.E. (Automatic Test Equipment)
- Switching Equipment
- Isolation Amplifiers
- Load Control From Microprocessor I/O Ports
- Thermocouple Open Detectors

Description:

The photovoltaic MOSFET-driver is a State-of-the-Art, optically coupled floating power source used primarily to control MOSFETs or IGBTs when electrical isolation between input and output is required.

In addition to the infrared LED and photovoltaic (PV) diode array, each of the DD (Dynamic Discharge) products contains circuitry that rapidly discharges the power MOSFET gate when the LED is deactivated. The unique rapid discharge features of the photovoltaic MOSFET-drivers make them particularly useful for high-side switching of N-channel MOSFETs in solid-state relays, DC motor control and switching regulator applications.

The typical input circuit to the LED is a limiting resistor connected in series with the LED. When activated, the LED emits infrared light towards the photovoltaic diode array, which then responds by generating an open circuit voltage (V_{oc}), thus disabling the turn-off circuitry. The self-limiting photovoltaic output of the diode array is floating and therefore, can be safely applied directly to the gate and source of a MOSFET, regardless of the source potential of the MOSFET. When the LED is deactivated, the active turn-off circuit discharges the capacitive input of the MOSFET. The active turn-off circuitry is designed such that the turn-off time of the MOSFET is relatively independent of the input capacitance of the MOSFET over a range of 50 to 5000 pF. Standard packages include low cost plastic mini-dips and hermetic 8-pin DIP ceramic side brazed.

❖ Package Layout:

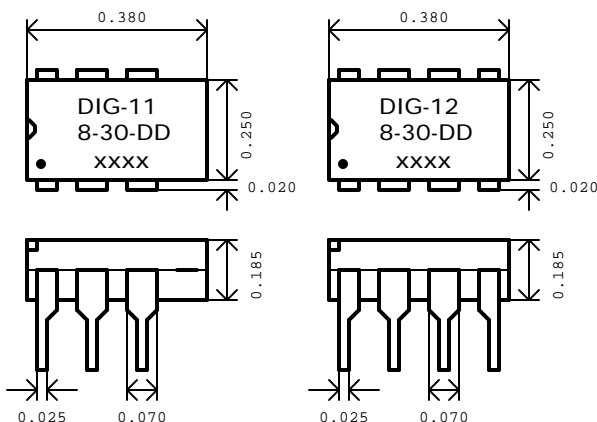

Pin Designation			
Pin Number	Part Number		
	11-8-30-DD	12-8-30-DD	22-8-30-DD
1	Input +	Input +	Input 1+
2	Input -	Input -	Input 1-
3	Not Connected	Not Connected	Input 2+
4	Not Connected	Not Connected	Input 2-
5	Not Connected	Output 1+	Output 2+
6	Output +	Output 1-	Output 2-
7	Not Connected	Output 2+	Output 1+
8	Output -	Output 2-	Output 1-

DIG-11-8-30-DD; DIG-12-8-30-DD; DIG-22-8-30-DD Equivalent Circuits:

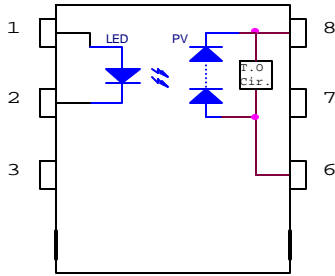

DIG-11-8-30-DD

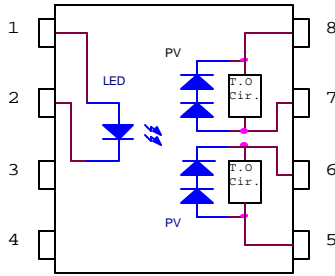

DIG-12-8-30-DD

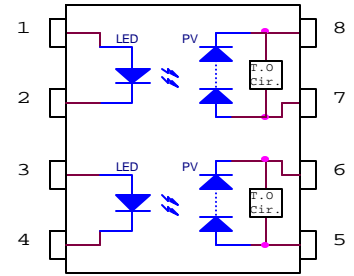

**DIG-22-8-30-DD
Ceramic Package Only**

❖ Absolute Maximum Ratings ($T_a = 25\text{ }^\circ\text{C}$)		
LED Forward Current	Steady State	100 mA
LED Forward Current	Peak 10% Duty Cycle	250 mA
LED Reverse Voltage		10V
Output Discharge Current		50mA
Operating Temperature Range	Plastic D.I.P	-40 to 85 $^\circ\text{C}$
Operating Temperature Range	Side Braze D.I.P	-50 to 125 $^\circ\text{C}$
Storage Temperature		-50 to 125 $^\circ\text{C}$
Power Dissipation		250 mW

❖ Individual Channel Electrical Characteristics ($T_a = 25\text{ }^\circ\text{C}$)

<i>Model Number</i>	<i>DIG-</i>	<i>11-8-30-DD; 12-8-30-DD; 22-8-30-DD</i>			<i>Unit</i>
Parameter & Test Condition	Symbol	Min.	Typ.	Max.	
Open Circuit Voltage*	V_{oc}				
$I_{led} = 2\text{mA}$		8.5	9.5	-	V
$I_{led} = 10\text{mA}$		9.5	10.5	-	V
$I_{led} = 30\text{ mA}; 50\% \text{ Duty Cycle}$		10.5	11.5	-	V
Short Circuit Current	I_{sc}				
$I_{led} = 2\text{mA}$		1.0	3.0	-	μA
$I_{led} = 10\text{mA}$		10.0	15.0	-	μA
$I_{led} = 30\text{ mA}; 50\% \text{ Duty Cycle}$		30.0	50.0	-	μA
LED Forward Voltage	V_f				
$I_f = 20\text{mA}$					
DIG-11-8-30-DD		-	1.3	1.7	V
DIG-12-8-30-DD		-	2.6	3.4	V
DIG-22-8-30-DD		-	1.3	1.7	V
LED Reverse Current	I_r				
$V_r = 5\text{V}$		0.1	10.0		μA
Off State Voltage	V_{off}				
$I_{off} = 10\mu\text{A}; I_{led} = 0\text{mA}$		-	0.65	1.0	V
Isolation Voltage	V_{iso}	2500	-	-	VDC
Temperature Coefficients	$\frac{\partial V}{\partial T}$	-	45	-	$\text{mV}/^\circ\text{C}$
$I_{led} = 10\text{mA}$	$\frac{\partial I}{\partial T}$	-	0.5	-	$\%I/^\circ\text{C}$
Turn-On Time	T_{on}				
$I_{led} = 30\text{ mA}$		-	100	-	μs
$C = 1500\text{pF}; V_{oc} \text{ to } 10\%$					
Turn-Off Time**	T_{off}				
$I_{led} = 30\text{ mA}$		-	3.0	6.0	μs
$C = 1500\text{pF}; V_{oc} \text{ to } 50\%$					

* Ceramic version differs. Contact factory for specifications

** For proper turn-off operation, gate must be charged to 90% of its final value before turn-off initiated

Typical Applications

1. Power MOSFET Photovoltaic SPST N/O AC-DC Relays

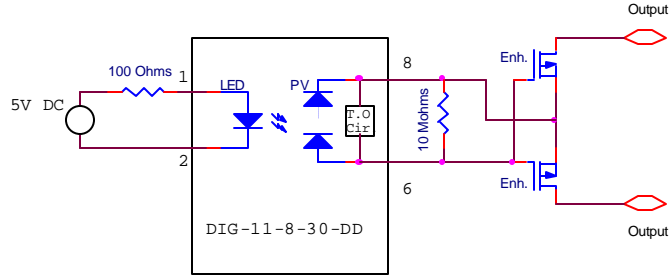

2. Power MOSFET SPDT Photovoltaic DC Relays:

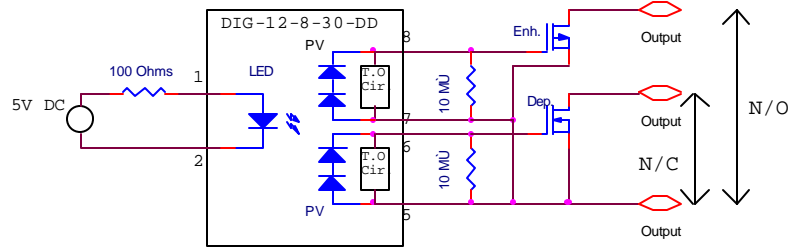

3. Power MOSFET Photovoltaic SPST N/O Relays With Short Circuit Protection:

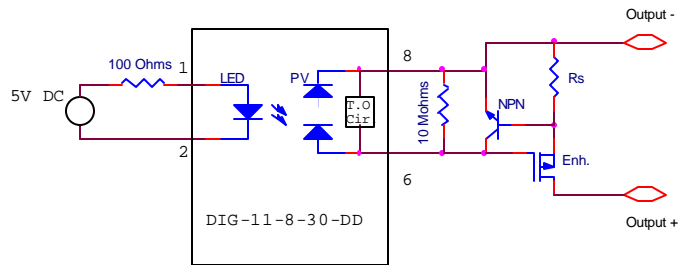

4. Totem Pole Output Drive:

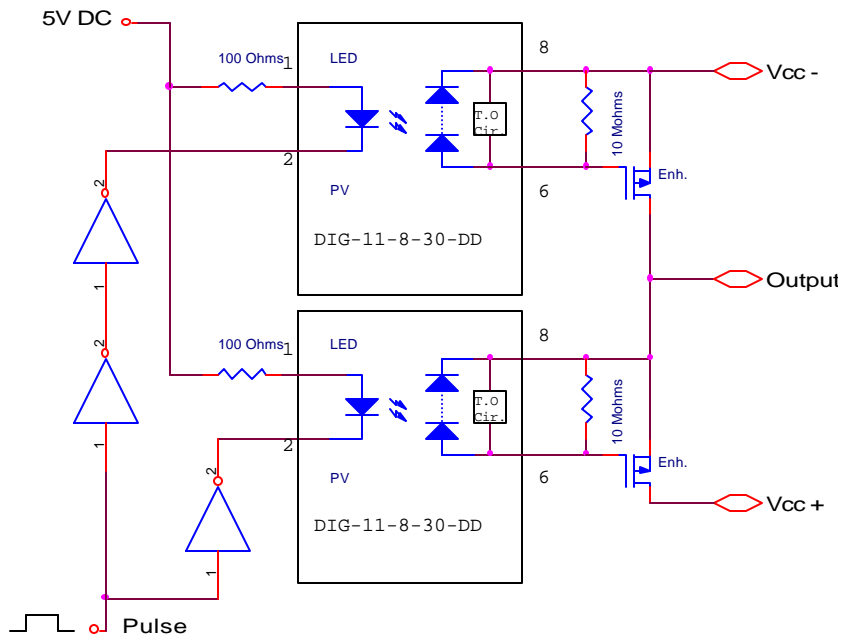

5. Battery Backup Switching:

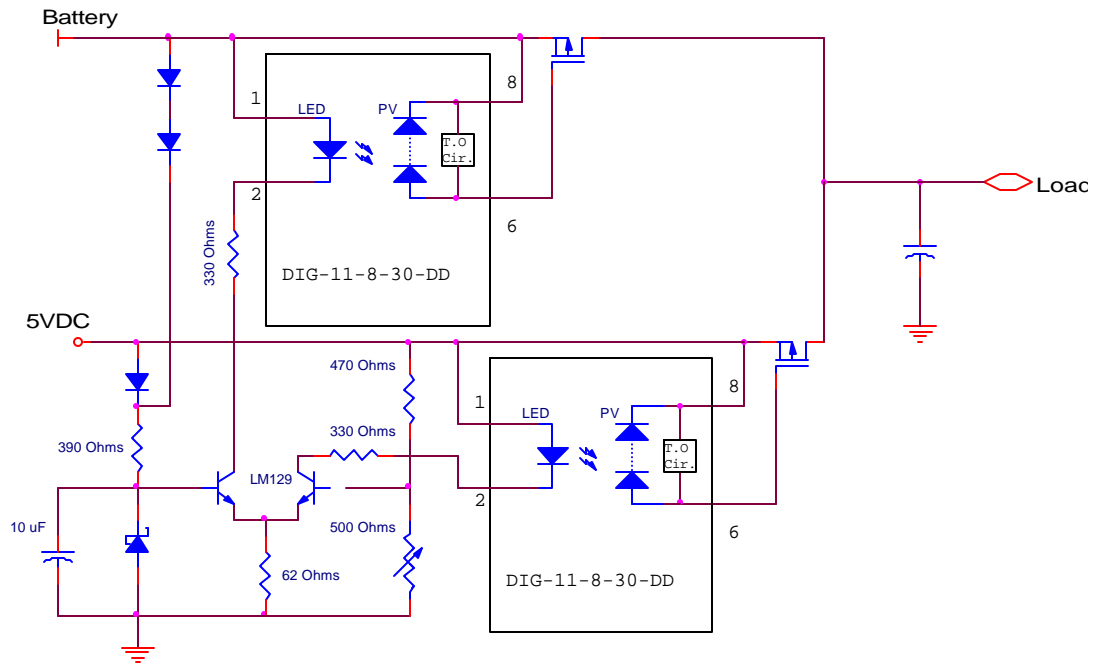

6. Directional Motor Control Drive:

